

INSTRUCTION MANUAL

VBHU Universal Facing & Boring Head 5 - 250mm



M185

UNIVERSAL BORING HEAD DIRECTIONS FOR OPERATION

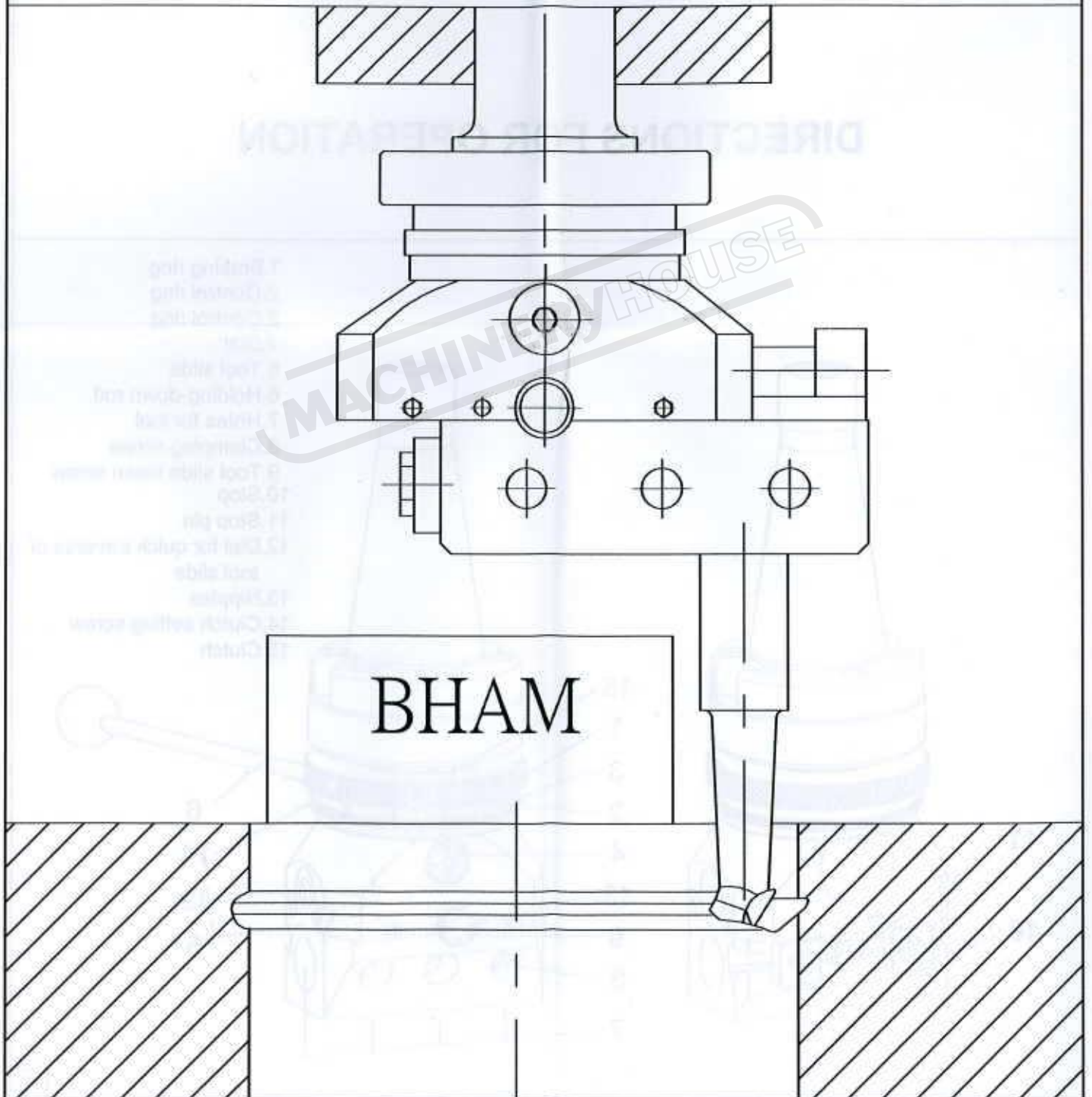

Application :

The universal boring head type BHAM is suitable for boring surface external turning, external , internal recessing and thru cutting operations.

When automatic cross feed to the tool slide to combine with feed spindle of the respective machine, it is possible to perform the tapered holes and cut tapered threads. The angle taper can be done for respective machines.

The BHAM universal boring head considerably increases the field application for the jig boring machines.

DIRECTIONS FOR OPERATION

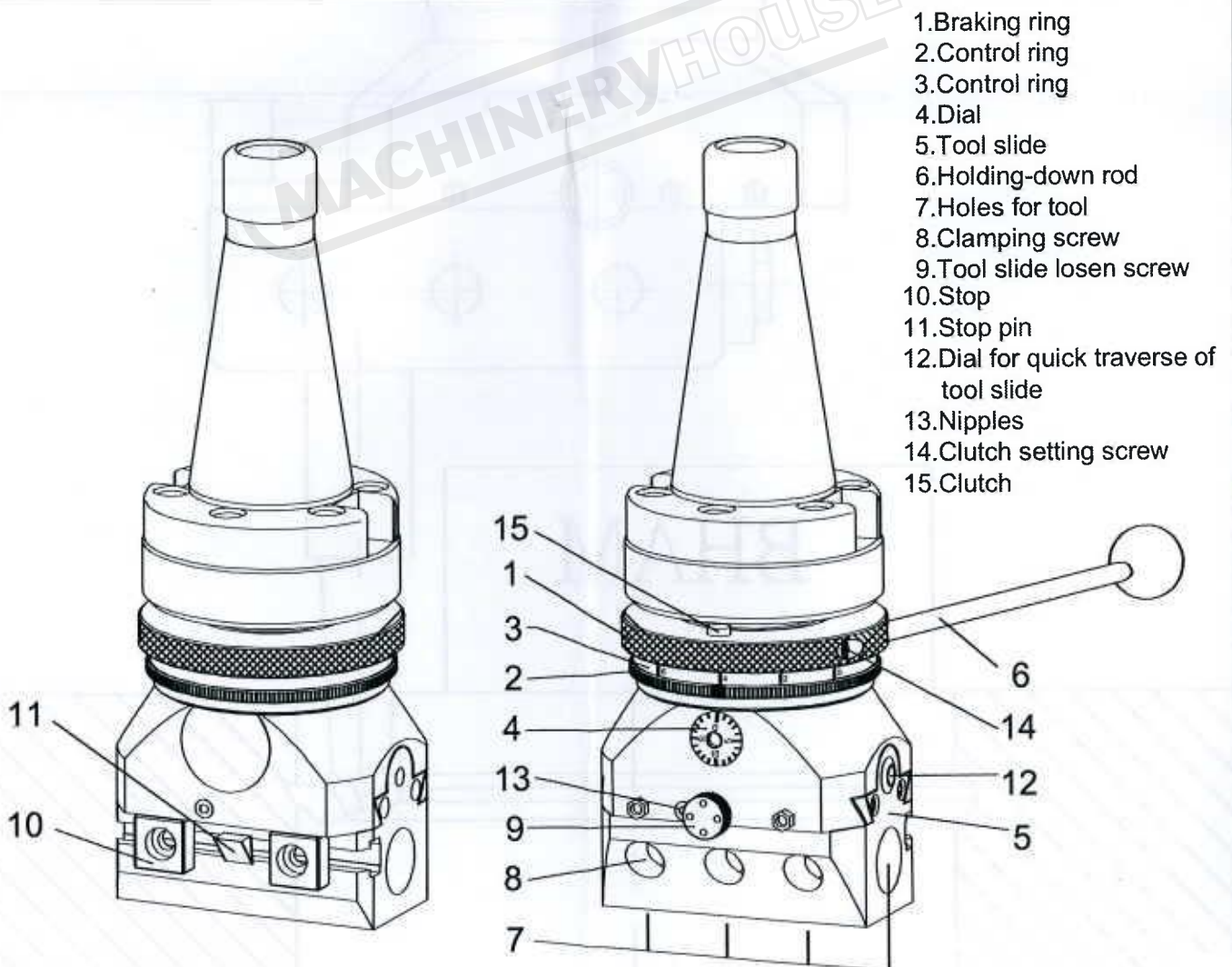

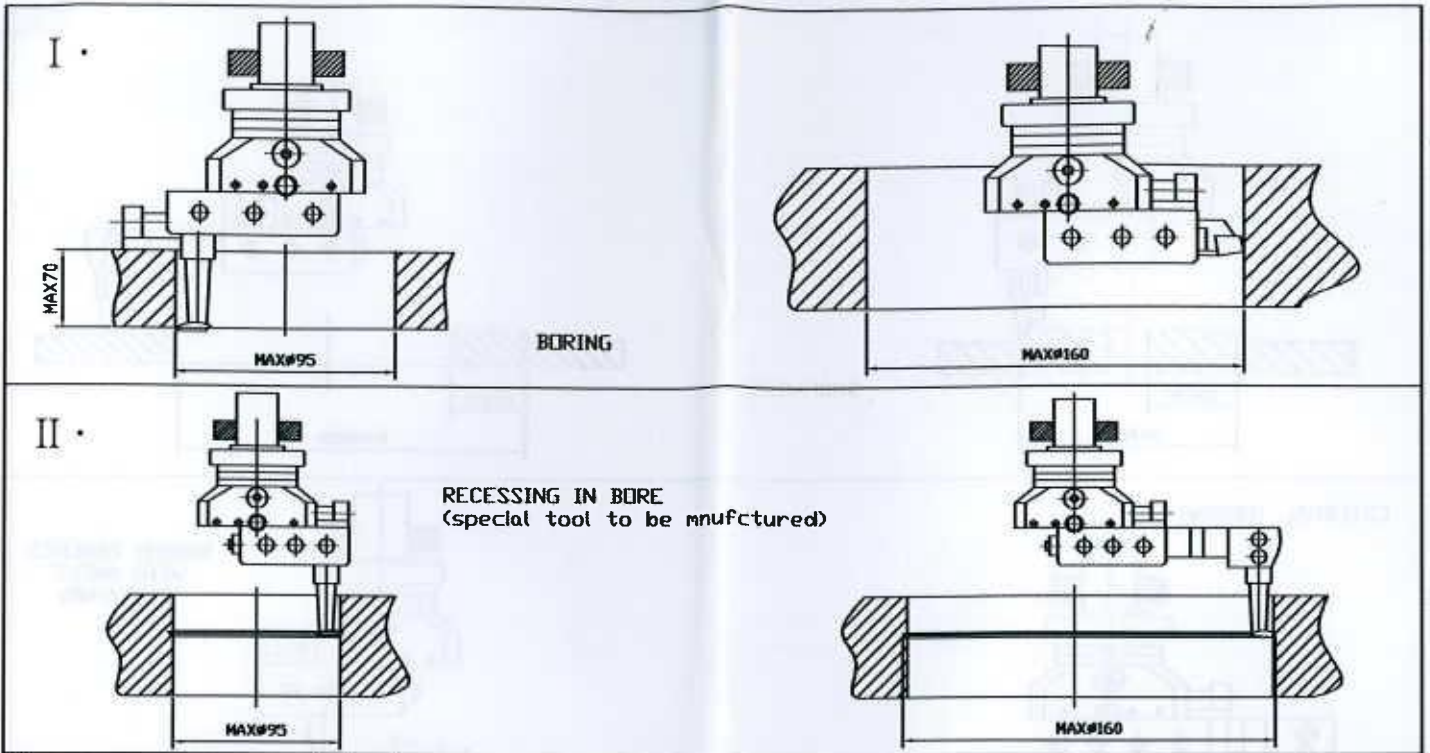

I · Boring and External Turning

In boring external turning with the BHAM head, must not be engaged the working feed as actuation of the braking ring (1) might result in a change of set dimension.
 The tools are clamped in holes (7) with the aid of the fixing screws (8). They are set in position by turning the graduating scale (4). One division equals displacement of tools slide by 0.005mm-0.01mm as a measurement of diameter.
 For precision re-setting of the tool from a larger dimension to a smaller one, the graduating scale (4) has to be turned backward by more than half a turn beyond the required dimension. Only then, should the dial be turned forward to the required dimension.
 In this manner, backlash in transmission gearing will be eliminated. Tightening of the screw (9) will help as well.
 The tool being set to the required dimension, it can be secured in its position by the screw (9) serving to lock the tool slide.

II · Surfacing Front and Rear Faces and Turning External and Internal Recesses

- a) The above operations call cross feed to the tool slide (5). Therefore, the tool slide locking screw (9) must be loosened.
- b) The BHAM universal boring head provides the following automatic cross feed to the tool slide : 0.02, 0.04 and 0.06mm/rev. The required feed is set as follows : the control ring (2) has to be turned until the red gauge line on the control ring points against the red hole attached to the figure expressing the feed rate in 0.01mm/rev. and is located on the graduating scale for automatic crossfeed (17). The selected feed is the best engaged as follows : the control ring (2) has to be gripped on its knurled part by the thumb and forefinger of one hand, whereas the braking ring (1) (clutch 15 being thrown-in) is gripped by the thumb and forefinger of the other hand. There after, the selected feed is engaged by turning the two rings against each other. Figure 1 shows the example of feed engagement. It shows engagement cross feed to the tool slide of 0.04mm/rev.

In all operations calling for automatic feed to tool slide it is always necessary to disengage this feed. For safety the feed has to be engaged while the machine is at a standstill.

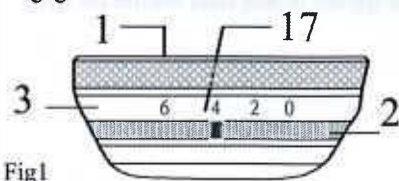

- 1.braking ring
- 17.graduating scale of cross feed
- 3.control ring
- 2.feed engaging ring

Table of recommended widths of the chip to be taken in surfacing front faces

cross feed to slide	up to dia of surfacing	max width of cutting pass in mm	up to dia of surfacing	max width of cutting pass in mm
0.04	90	3	200	2

The table applies to cutting steel of 500-800 MPa/sq. mm tensile strength.

The required cross feed being engaged, the braking ring (1) has to be turned by a minimum of one turn in the opposite direction to the spindle rotation, while the machine is at a standstill! Maximum permissible spindle speed is 800 r.p.m.!

c) The automatic cross feed to the tool slide (5) is started by braking the control ring (3) by means of the braking ring (1). The holding-down rod (16) has to be slid into the hole provided in the braking ring and leans against the fixed stop which should be suitably located near the machine spindle. In case of light duty work of short duration, the rod can be held by hand. In both cases, however, the braking ring (1) must be coupled to the control ring (3) by means of the clutch (15) located in the braking ring (1). The clutch has to be pressed by the finger into one of the notches provided in the control ring (3).

d) The cross feed is automatically tripped when one of the stops (10) actuates the stop pin (11) of when cutting resistance increases, because of a too large cut is being taken or there is the tool blunting or breaking. Sensitiveness of the clutch disengagement (15) can be set by means of the clutch setting screw (14). With this screw we compress of release a spring acting against the clutch (15). If the clutch setting screw (14) is screwed in deeply, try to disengage the clutch with a screwdriver (see Fig_2).

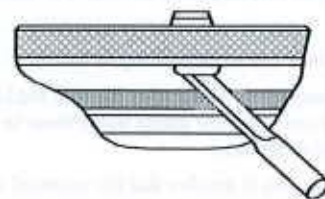
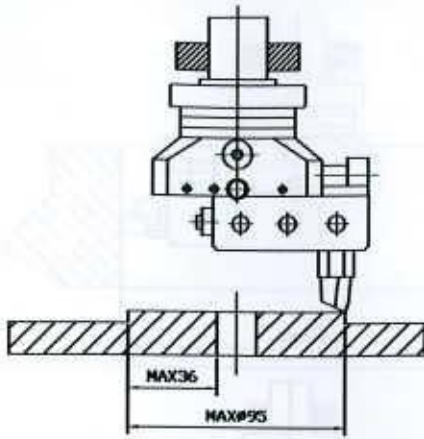
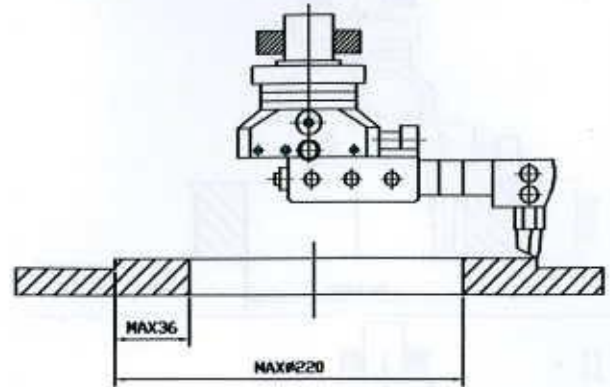

Fig.2

In case the clutch cannot be disengaged completely. It means that the spring coils are bearing against each other and it is necessary to slightly loosen the clutch setting screw(14). Then, attempt to disengage the clutch (15) in the manner described above.



SURFACING

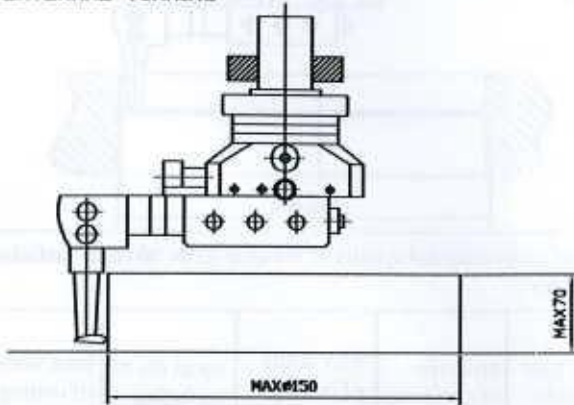
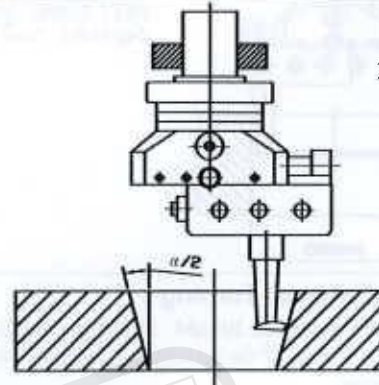

EXTERNAL TURNING

BORING TAPERED
WITH ANGLE
 $\alpha/2=5+85$ 

e) Setting the stop for feed tripping as the required diameter is obtained. The stop (10) must be set and secured in such a manner that the cross feed to the tool slide is tripped at the moment when the cutting edge reached the required diameter. Therefore, disengagement of clutch (15) has to be set to that the disengaging force produced by the stop (10) on the stop pin (11) is as small as possible. In other words, the clutch setting screw (14) has to be screwed-in as little as possible.

Despite this, however, a certain amount of the over-run of required dimension always in axes place. This over-run is within the tolerance of the diameter of recesses made for locking rings. In case of jobs calling for closer precision limits, the stop can be set according to the following instructions :

A) The stop (10) must be set and firmly screwed-in so that in causes the feed to be tripped closely before the required diameter is reached. For example, the tool slide (5) is adjusted rearwards about 0.2mm by turning graduating scale (4), the stop (10) is thrust against the stop pin (11) and firmly secured by the screw. After a try-out of feed tripping (clutch disengagement), the difference between the required and actual diameters should ascertained by a gauge.

B) Now, the stop has to be set in the following way :

- a) The stop (10) should not be loosened. The tool slide (5) however, has to be adjusted rear ward so that a gauge block of any size (e.g. 2mm) can be slide between the stop (10) and stop pin (11).
- b) The tool slide (5) has to be secured against movement by the tool slide locking screw (9) so that its position remains unchanged while the stop (10) is adjusted.

c) A new gauge block has to be built-up as follows :

1) if the actual diameter obtained after the trial feed tripping is larger than the required one, the new gauge block must be thinner than 2 mm by half the found difference.

1) if the actual diameter is smaller that the required one, the new gauge block must be thicker than 2 mm by half the found difference.

d) Thereafter the stop (10) should be loosened and thrust against the newly built-up gauge block to lean against the stop pin (11). The stop should be thrust against the gauge block and firmly secured.

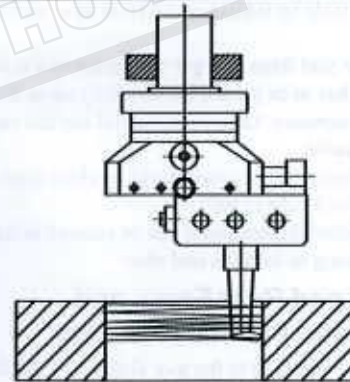
CUTTING THREAD
(by means of spec
tool)

e) The gauge block must be taken out and the tool slide locking screw (g) loosened. Tripping of automatic cross feed is thus set to the required diameter.

To achieve a rapid resetting of the tool slide (5) it is necessary to force an extension socket spanner into the internal hexagon of the dial of rapid feed motion (12) to a depth of approx 5 mm. The tool slide can be now quickly traversed by turning.

One division of the dial of quick traverse of the tool slide stands for the feed motion of the tool slide by 1 mm - 2 mm on dia.

One turn of the screw for rapid feed traverse of the tool slide stands for the feed motion of the tool slide by 3 mm- 6 mm on dia.

After the slide has been reset, the quick traverse screw must be re-locked against turning. Pull out the socket spanner partly so that a length of only 2.5 mm will remain in the hole, then turn the screw in order to set the nearest scale line against the fixed scale mark of the tool slide (5). Check by turning the spanner to both sides whether the screw is secured against turning.

III · Taper boring

For taper boring the cross feed to the tool slide must be combined with the axial feed to the machine spindle.

a) Selection of feeds to the tool slide and spindle accordingly it is possible to select the necessary feed to the tool slide and spindle from "taper boring diagram" (see enclosure). From this diagram it follows that for an angle of taper of 60° it is possible to use a tool slide feed of 0.04 mm/rev. From the diagram the feed to spindle in mm/min. in relation with spindle r.p.m. can be fixed. Endeavour should be always made to select as low a rate of spindle feed as possible. However, in boring tapers of small angles, it is not possible to eliminate feeds, of considerable rates, which have a deteriorating effect on the surface finish obtained. The taper surface has 0.02 mm unevenness caused by the interrupted cross feed. Therefore, precision taper bores have to be calibrated supplementarily with some other tool.

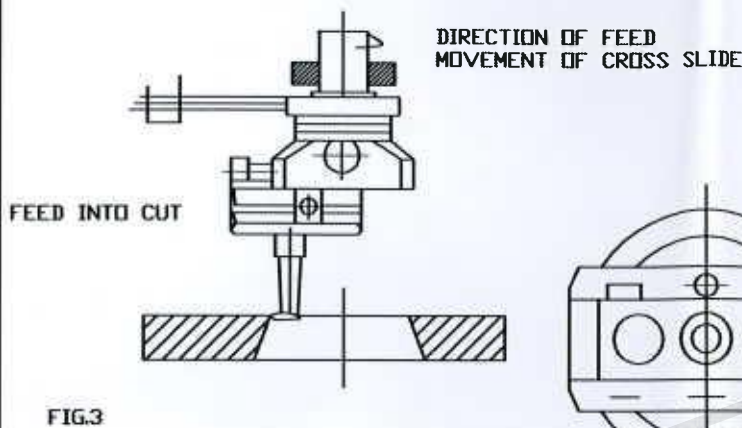

FIG.3

b) Tool clamping

In case of spindle rotation in clockwise direction, the feed movement of the tool slide (5) can operate in one direction only (see Fig.3). Despite this, it is possible to bore expanding or contracting taper bores.

The tool being clamped in the direction of cross feed to the tool slide, expanding taper is produced. If the same tool is clamped in the opposite direction to the direction of cross feed to tool slide, contracting taper will be produced. When clamping the tool it is necessary to see it that the tool point is set in a plane passing through the axis of holes for bars and holders (7) (see Fig.4). Otherwise, the taper bore will not be accurate.

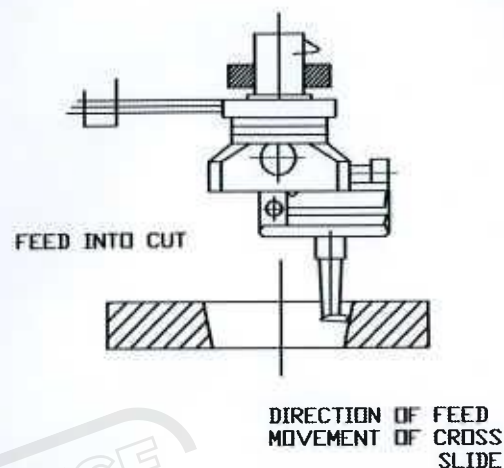

FIG.4

c) Procedure to be followed in taper boring :

- 1) the tool has to be clamped according to instruction given in item b) and set to the starting diameter of boring with the aid of the dial (4).
- 2) the spindle has to be advanced so that the tool cutting edge is about 2-3 mm above the surface of the work. In this position, the dial of the tool slide has to be set to "0".
- 3) the spindle has to be retracted by a few millimeters and advanced to "0" with the spindle feed selected according to the diagram. The "0" setting being accomplished, the machine has to be stopped. However, the feed should not be disengaged.
- 4) the stop has to be set according to Fig 3 and secured.
- 5) the clutch (15) has to be thrown - in and the clutch setting screw (14) completely screwed-in. Thereby, clutch disengagement in case of an overload is avoided. For this reason, however, increased attention has to be paid when working.
- 6) the holding-down rod (6) has to be slid in the hole in the braking ring (1) and lean against the steady stop provided on the machine.
- 7) now, start the machine. Simultaneously with the spindle feed movement the tool slide (5) also moves : thus producing the required taper bore.
- 8) the boring operation being completed, the holding-down rod (6) has to be slid out, the boring head returned to its starting position and by means of the stop (10) and gauge block of by means of the graduated dial (4) the next cut has to be set. This procedure is repeated according to the need. External tapers can be turned in a similar way.

Lubrication :

The internal mechanism of the boring head is lubricated with vaseline force-fed in two nipples (13) with a hand grease gun.

We hope that the BHAM universal boring head will enable you to carry out on your boring machines the most accurate and intricate operations with success.

IV · Thread Cutting

Procedure :

- 1) tool is clamped
 - 2) the feed rate corresponding to the thread pitch is selected
 - 3) the depth of the cut is set by the graduated dial
 - 4) the machine is started, we cut the thread and then we stop the machine
 - 5) the tool is withdrawn by the graduated dial (4)
 - 6) we take the next cut and the whole process is repeated if necessary.
- To a limited extent, also tapered threads can be cut with the BHAM universal boring head. Axial feed to the machine spindle controls the thread pitch, whereas the actual cutting thread is accomplished by cross feed to the tool slide. During thread cutting both feed must be continuously in operation. The tool slide cross feed is calculated from this formula :
- $$\text{tool slide cross feed in mm/rev.} = \frac{\text{pitch of thread in mm}}{\text{ctg } \alpha / 2}$$
- For tool clamping and setting to the required diameter the same instructions as in case of taper boring apply.